

Molex 22-28-8130 PDF

深圳创唯电子有限公司

<http://www.molex-connect.com>

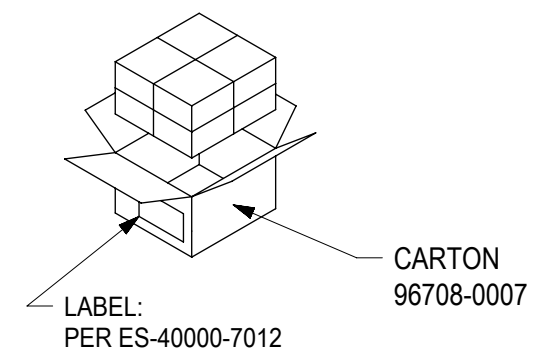

96708-0007 CARTON
HOLDS 8
96707-0012 INNER BOXES

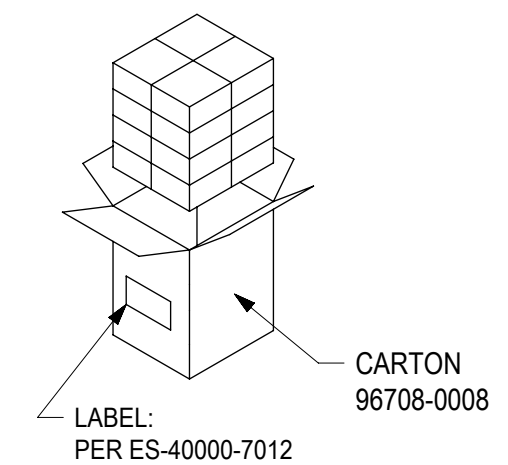

96708-0008 CARTON
HOLDS 16
96707-0012 INNER BOXES

CIRCUITS 2-28

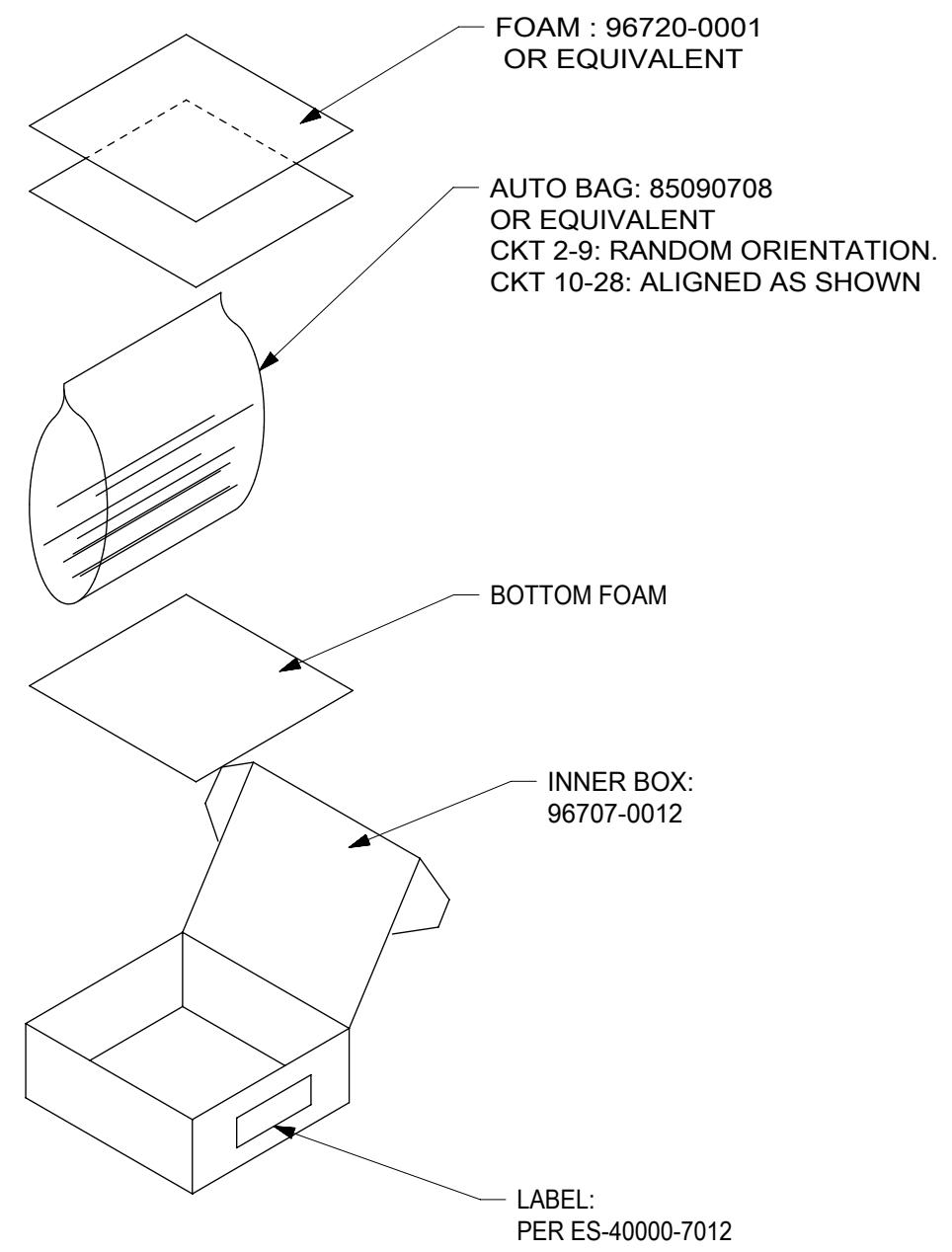

CIRCUITS 29-36

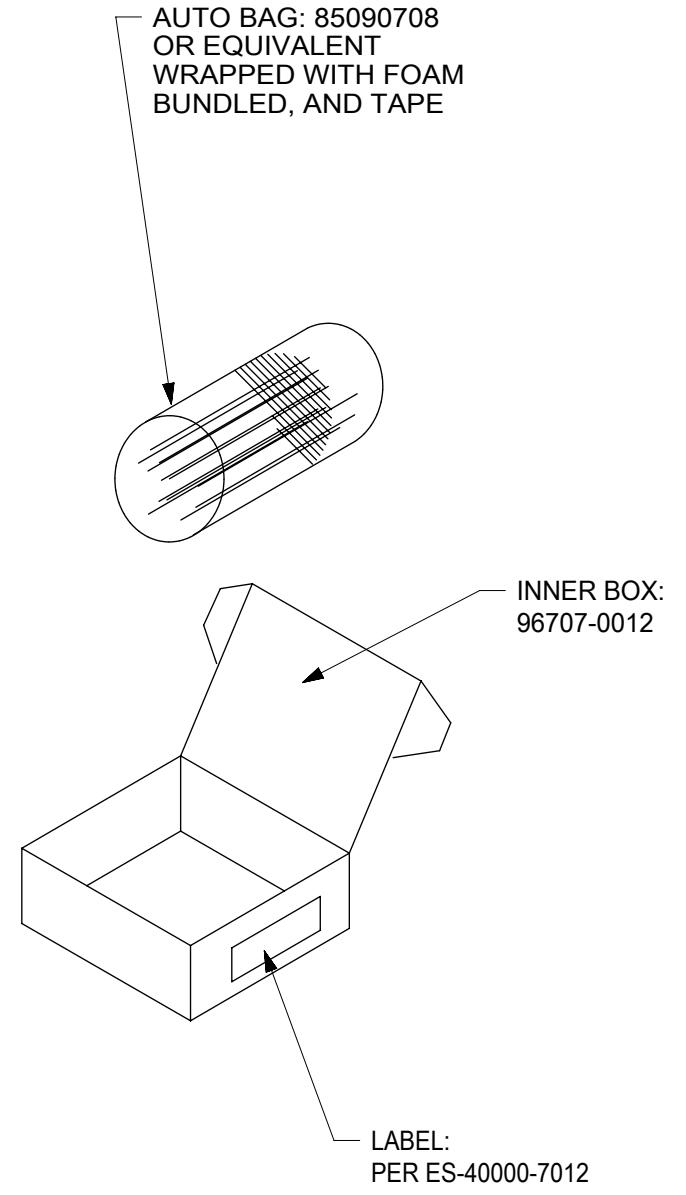

- NOTES:
1. BAGS ARE HEAT SEALED WITH AUTO BAGGER.
 2. LAYER PACK:
CKTS 2-28: WITH FOAM
CKTS 29-36: WRAP WITH FOAM, BUNDLE AND TAPE
 3. ENOUGH FOAM SHOULD BE ADDED TO EACH BOX TO PREVENT PARTS FROM RATTLING.
 4. THIS PACKAGING DOES NOT APPLY TO P/N'S 42377-0955 THRU 42377-0962. SEE "SPECIAL PACKAGING FOR MAT'L NO'S 42377-0955 / -0962".

| | | | | | | | | | |
|---|--|-----------------|------------------------|-------|---------|------------------------------------|--------|----------------|-----------------|
| THIS DRAWING CONTAINS INFORMATION THAT IS PROPRIETARY TO MOLEX ELECTRONIC TECHNOLOGIES, LLC AND SHOULD NOT BE USED WITHOUT WRITTEN PERMISSION | | | | | | | | | |
| SYMBOLS | | DIMENSION UNITS | | SCALE | | CURRENT REV DESC: DRAWING UPDATION | | | |
| ▽ = 0 | IN/MM | NTS | | | | EC NO: 612141 | | | |
| ▽ = 0 | GENERAL TOLERANCES (UNLESS SPECIFIED) | | | | | DRWN: SS06 2019/01/29 | | | |
| ▽ = 0 | | MM | INCH | | | CHK'D: ISHWARG 2019/02/15 | | | |
| ▽ = 0 | 4 PLACES ± | | | | | APPR: ISHWARG 2019/02/15 | | | |
| ▽ = 0 | 3 PLACES ± | | | | | INITIAL REVISION: | | | |
| ▽ = 0 | 2 PLACES ± | | | | | DRWN: JJS 1989/03/27 | | 1989/03/27 | |
| ▽ = 0 | 1 PLACE ± | | | | | APPR: LENZ 1989/03/27 | | | |
| ▽ = 0 | 0 PLACES ± | | | | | ANGULAR TOL ± ° | | | |
| ■ = 0 | DRAFT WHERE APPLICABLE MUST REMAIN WITHIN DIMENSIONS | | THIRD ANGLE PROJECTION | | DRAWING | | SERIES | | MATERIAL NUMBER |
| ▽ = 0 | | | B-SIZE | | 40873 | | NA | | CUSTOMER |
| | | | | | | | | GENERAL MARKET | |
| | | | | | | | | SHEET NUMBER | |
| | | | | | | | | 1 OF 2 | |

| CKTS | 42375 | | | | | 42376 | | | | | 42377/46006 SEE NOTE 4 | | | | |
|------|---------------|--------------------|---------------------|---------------------------------------|---------------------------------------|---------------|--------------------|---------------------|---------------------------------------|---------------------------------------|---------------------------|--------------------|---------------------|---------------------------------------|---------------------------------------|
| | PARTS PER BAG | BAGS PER INNER BOX | PARTS PER INNER BOX | PARTS PER MASTER CARTON 96708-0007 DU | PARTS PER MASTER CARTON 96708-0008 DU | PARTS PER BAG | BAGS PER INNER BOX | PARTS PER INNER BOX | PARTS PER MASTER CARTON 96708-0007 DU | PARTS PER MASTER CARTON 96708-0008 DU | PARTS PER BAG | BAGS PER INNER BOX | PARTS PER INNER BOX | PARTS PER MASTER CARTON 96708-0007 DU | PARTS PER MASTER CARTON 96708-0008 DU |
| 2 | 1250 | 3 | 3750 | 30000 | 60000 | 1250 | 3 | 3750 | 30000 | 60000 | 1250 | 3 | 3750 | 30000 | 60000 |
| 3 | 1250 | 3 | 3750 | 30000 | 60000 | 1250 | 3 | 3750 | 30000 | 60000 | 1250 | 3 | 3750 | 30000 | 60000 |
| 4 | 1000 | 3 | 3000 | 24000 | 48000 | 1000 | 3 | 3000 | 24000 | 48000 | 1000 | 3 | 3000 | 24000 | 48000 |
| 5 | 500 | 3 | 1500 | 12000 | 24000 | 500 | 3 | 1500 | 12000 | 24000 | 500 | 3 | 1500 | 12000 | 24000 |
| 6 | 500 | 3 | 1500 | 12000 | 24000 | 500 | 3 | 1500 | 12000 | 24000 | 500 | 3 | 1500 | 12000 | 24000 |
| 7 | 500 | 3 | 1500 | 12000 | 24000 | 500 | 3 | 1500 | 12000 | 24000 | 500 | 3 | 1500 | 12000 | 24000 |
| 8 | 250 | 3 | 750 | 6000 | 12000 | 250 | 3 | 750 | 6000 | 12000 | 250 | 3 | 750 | 6000 | 12000 |
| 9 | 250 | 3 | 750 | 6000 | 12000 | 250 | 3 | 750 | 6000 | 12000 | 250 | 3 | 750 | 6000 | 12000 |
| 10 | 250 | 3 | 750 | 6000 | 12000 | 250 | 3 | 750 | 6000 | 12000 | 250 | 3 | 750 | 6000 | 12000 |
| 11 | 250 | 3 | 750 | 6000 | 12000 | 250 | 3 | 750 | 6000 | 12000 | 250 | 3 | 750 | 6000 | 12000 |
| 12 | 250 | 3 | 750 | 6000 | 12000 | 250 | 3 | 750 | 6000 | 12000 | 250 | 3 | 750 | 6000 | 12000 |
| 13 | 250 | 3 | 750 | 6000 | 12000 | 250 | 3 | 750 | 6000 | 12000 | 250 | 3 | 750 | 6000 | 12000 |
| 14 | 250 | 3 | 750 | 6000 | 12000 | 125 | 3 | 375 | 3000 | 6000 | 250 | 3 | 750 | 6000 | 12000 |
| 15 | 250 | 3 | 750 | 6000 | 12000 | 75 | 3 | 225 | 1800 | 3600 | 250 | 3 | 750 | 6000 | 12000 |
| 16 | 250 | 3 | 750 | 6000 | 12000 | 75 | 3 | 225 | 1800 | 3600 | 250 | 3 | 750 | 6000 | 12000 |
| 17 | 125 | 3 | 375 | 3000 | 6000 | 75 | 3 | 225 | 1800 | 3600 | 125 | 3 | 375 | 3000 | 6000 |
| 18 | 125 | 3 | 375 | 3000 | 6000 | 75 | 3 | 225 | 1800 | 3600 | 125 | 3 | 375 | 3000 | 6000 |
| 19 | 125 | 3 | 375 | 3000 | 6000 | 75 | 3 | 225 | 1800 | 3600 | 125 | 3 | 375 | 3000 | 6000 |
| 20 | 125 | 3 | 375 | 3000 | 6000 | 75 | 3 | 225 | 1800 | 3600 | 125 | 3 | 375 | 3000 | 6000 |
| 21 | 125 | 3 | 375 | 3000 | 6000 | 75 | 3 | 225 | 1800 | 3600 | 125 | 3 | 375 | 3000 | 6000 |
| 22 | 125 | 3 | 375 | 3000 | 6000 | 75 | 3 | 225 | 1800 | 3600 | 125 | 3 | 375 | 3000 | 6000 |
| 23 | 125 | 3 | 375 | 3000 | 6000 | 75 | 3 | 225 | 1800 | 3600 | 125 | 3 | 375 | 3000 | 6000 |
| 24 | 125 | 3 | 375 | 3000 | 6000 | 75 | 3 | 225 | 1800 | 3600 | 125 | 3 | 375 | 3000 | 6000 |
| 25 | 125 | 3 | 375 | 3000 | 6000 | 75 | 3 | 225 | 1800 | 3600 | 125 | 3 | 375 | 3000 | 6000 |
| 26 | 125 | 3 | 375 | 3000 | 6000 | 75 | 3 | 225 | 1800 | 3600 | 125 | 3 | 375 | 3000 | 6000 |
| 27 | 125 | 3 | 375 | 3000 | 6000 | 75 | 3 | 225 | 1800 | 3600 | 125 | 3 | 375 | 3000 | 6000 |
| 28 | 125 | 3 | 375 | 3000 | 6000 | 75 | 3 | 225 | 1800 | 3600 | 125 | 3 | 375 | 3000 | 6000 |
| 29 | 125 | 2 | 250 | 2000 | 4000 | 75 | 3 | 225 | 1800 | 3600 | 125 | 2 | 250 | 2000 | 4000 |
| 30 | 125 | 2 | 250 | 2000 | 4000 | 75 | 3 | 225 | 1800 | 3600 | 125 | 2 | 250 | 2000 | 4000 |
| 31 | 125 | 2 | 250 | 2000 | 4000 | 75 | 3 | 225 | 1800 | 3600 | 125 | 2 | 250 | 2000 | 4000 |
| 32 | 125 | 2 | 250 | 2000 | 4000 | 75 | 3 | 225 | 1800 | 3600 | 125 | 2 | 250 | 2000 | 4000 |
| 33 | 125 | 2 | 250 | 2000 | 4000 | 75 | 3 | 225 | 1800 | 3600 | 125 | 2 | 250 | 2000 | 4000 |
| 34 | 125 | 2 | 250 | 2000 | 4000 | 75 | 3 | 225 | 1800 | 3600 | 125 | 2 | 250 | 2000 | 4000 |
| 35 | 125 | 2 | 250 | 2000 | 4000 | 75 | 3 | 225 | 1800 | 3600 | 125 | 2 | 250 | 2000 | 4000 |
| 36 | 125 | 2 | 250 | 2000 | 4000 | 75 | 3 | 225 | 1800 | 3600 | 125 | 2 | 250 | 2000 | 4000 |

| SPECIAL PACKAGING FOR MAT'L NO'S 42377-0955/-0962 | | | | | |
|--|---------------|--------------------|---------------------|---------------------------------------|---------------------------------------|
| CKTS | PARTS PER BAG | BAGS PER INNER BOX | PARTS PER INNER BOX | PARTS PER MASTER CARTON 96708-0007 DU | PARTS PER MASTER CARTON 96708-0008 DU |
| 29 | 75 | 2 | 150 | 1200 | 2400 |
| 30 | 75 | 2 | 150 | 1200 | 2400 |
| 31 | 75 | 2 | 150 | 1200 | 2400 |
| 32 | 75 | 2 | 150 | 1200 | 2400 |
| 33 | 75 | 2 | 150 | 1200 | 2400 |
| 34 | 75 | 2 | 150 | 1200 | 2400 |
| 35 | 75 | 2 | 150 | 1200 | 2400 |
| 36 | 75 | 2 | 150 | 1200 | 2400 |

| | | |
|---------|---|-------|
| SYMBOLS | THIS DRAWING CONTAINS INFORMATION THAT IS PROPRIETARY TO MOLEX ELECTRONIC TECHNOLOGIES, LLC AND SHOULD NOT BE USED WITHOUT WRITTEN PERMISSION | |
| | DIMENSION UNITS | SCALE |
| ▽ = 0 | IN/MM | NTS |
| ▽ = 0 | GENERAL TOLERANCES (UNLESS SPECIFIED) | |
| ▽ = 0 | | |
| ▽ = 0 | 4 PLACES ± | ± |
| ▽ = 0 | 3 PLACES ± | ± |
| ▽ = 0 | 2 PLACES ± | ± |
| ▽ = 0 | 1 PLACE ± | ± |
| ▽ = 0 | 0 PLACES ± | ± |
| ⊠ = 0 | ANGULAR TOL ± ° | |
| ■ = 0 | DRAFT WHERE APPLICABLE MUST REMAIN WITHIN DIMENSIONS | |
| ▽ = 0 | | |

| | | |
|------------------------------------|------------|--------|
| CURRENT REV DESC: DRAWING UPDATION | | |
| EC NO: 612141 | 2019/01/29 | |
| DRWN: SS06 | 2019/02/15 | |
| CHK'D: ISHWARG | 2019/02/15 | |
| APPR: ISHWARG | 2019/02/15 | |
| INITIAL REVISION: | | |
| DRWN: JJS | 1989/03/27 | |
| APPR: LENZ | 1989/03/27 | |
| THIRD ANGLE PROJECTION | DRAWING | SERIES |
| | B-SIZE | 40873 |

| | | |
|---|----------------|--------------|
| molex | | |
| PACKAGING SPEC. .100/(2.54) BREAKAWAYS | | |
| PACKAGING DESIGN DRAWING | | |
| DOCUMENT NUMBER | DOC TYPE | DOC PART |
| PK-40873-0041 | PDD | 001 |
| REVISION | H3 | |
| MATERIAL NUMBER | CUSTOMER | SHEET NUMBER |
| NA | GENERAL MARKET | 2 OF 2 |

molex PRODUCT SPECIFICATION

1.0 SCOPE

This Product Specification covers the 2.54 mm (.100 inch) centerline (pitch) 0.64 mm (.025) square pin headers when mated with either printed circuit board (PCB) connectors or connectors terminated with 22 to 30 AWG wire using crimp technology.

2.0 PRODUCT DESCRIPTION

2.1 PRODUCT NAME AND SERIES NUMBERS

Crimp Terminals: 2759, 6459, 41572, 4809, 8088

Crimp Housings: 2695

PCB Connectors: 4455

Headers: 4030, 4094, 6373, 7478, 6410, 7395, 42225, 42226, 42227, 42228, 42375, 42376, 42377

Other products conforming to this specification are noted on the individual drawings.

2.2 DIMENSIONS, MATERIALS, PLATINGS AND MARKINGS

Terminal Material: Brass or Phos. Bronze (for Max performance use phos. bronze material.)

Housing: Nylon or Polyester

Pins: Brass or Phos. Bronze

For more information on dimensions, materials, and plating see the individual drawings.

2.3 SAFETY AGENCY APPROVALS

UL File Number E29179

CSALR19980

| SERIES | Agency Voltage Rating (AC RMS or DC) | | Agency Current Rating (Single Circuit) (Amps) | | Agency Temperature Rating (°C) |
|--------|--------------------------------------|-----|---|-----|--------------------------------|
| | UL | CSA | UL | CSA | UL |
| 2695 | 500 V AC 600 V DC | 250 | - | 2.5 | 105°C |
| 4455 | 600 | 250 | - | 2.5 | 105°C |
| 4030 | 600 | 250 | - | 2.5 | 105°C |
| 4094 | 600 | 250 | - | 2.5 | 105°C |
| 6373 | 600 | 250 | - | 2.5 | 105°C |
| 7478 | 600 | 250 | - | 2.5 | 105°C |
| 6410 | 600 | 250 | - | 2.5 | 105°C |
| 7395 | 600 | 250 | - | 2.5 | 105°C |
| 42225 | 600 | 250 | - | 2.5 | 105°C |
| 42226 | 600 | 250 | - | 2.5 | 105°C |
| 42227 | 600 | 250 | - | 2.5 | 105°C |
| 42228 | 600 | 250 | - | 2.5 | 105°C |
| 42375 | 600 | 250 | - | 2.5 | 120°C |
| 42376 | 600 | 250 | - | 2.5 | 120°C |
| 42377 | 600 | 250 | - | 2.5 | 120°C |

| | | | |
|-------------------------------------|--|--|--------------------------------|
| REVISION: T2 | ECM INFORMATION: ECM No: 604532 DATE: 17/09/2018 | TITLE: PRODUCT SPECIFICATION .100 CENTER KK CONNECTORS | SHEET No. 1 of 6 |
| DOCUMENT NUMBER: PS-10-07 | CREATED / REVISED BY: SS06 | CHECKED BY: SS06 | APPROVED BY: ISHWARG |

molex PRODUCT SPECIFICATION

3.0 APPLICABLE DOCUMENTS AND SPECIFICATIONS

None

4.0 RATINGS

4.1 VOLTAGE

500 Volts AC (or 600 Volts DC)

4.2 CURRENT AND APPLICABLE WIRES (Current is dependent on connector size, contact material, plating, ambient temperature, printed circuit board characteristics and related factors. Actual current rating is application dependent and should be evaluated for each application.)

| AWG | Amps (Max) | Outside Insulation Diameter |
|-----|------------|-----------------------------|
| 22 | 4.00 | See Drawings |
| 24 | 3.75 | See Drawings |
| 26 | 3.50 | See Drawings |
| 28 | 3.00 | See Drawings |
| 30 | 2.50 | See Drawings |

Note: current ratings are for a single circuit, based on not exceeding 30°C temperature rise.

4.3 TEMPERATURE (ambient +30°C temp)

| | Brass Terminals | Phos Bronze Terminals |
|---------------------------|-------------------|-----------------------|
| Operating Temperature | -40°C to +80°C* | -40°C to +105°C* |
| Non-Operating Temperature | -40°C to +105°C** | -40°C to +105°C |

*including terminal temperature rise.

**parts not mated

| | | | |
|-------------------------------------|--|--|--------------------------------|
| REVISION: T2 | ECM INFORMATION: ECM No: 604532 DATE: 17/09/2018 | TITLE: PRODUCT SPECIFICATION .100 CENTER KK CONNECTORS | SHEET No. 2 of 6 |
| DOCUMENT NUMBER: PS-10-07 | CREATED / REVISED BY: SS06 | CHECKED BY: SS06 | APPROVED BY: ISHWARG |

molex PRODUCT SPECIFICATION

5.0 PERFORMANCE

5.1 ELECTRICAL REQUIREMENTS

| DESCRIPTION | TEST CONDITION | REQUIREMENT |
|--|--|--------------------------------------|
| Contact Resistance (Low Level) | Mate connectors: apply a maximum voltage of 20 mV and a current of 100 mA. | 10 milliohms MAXIMUM [initial] |
| Contact Resistance of Wire Termination (Low Level) | Terminate the applicable wire to the terminal and measure wire using a voltage of 20 mV and a current of 100 mA. | 2 milliohms MAXIMUM [initial] |
| Insulation Resistance | Unmate & unmount connectors: apply a voltage of 500 VDC between adjacent terminals and between terminals to ground. | 1000 Megohms MINIMUM |
| Dielectric Withstanding Voltage | Unmate connectors: apply a voltage of {two times the rated voltage plus 1000 volts} VAC for 1 minute between adjacent terminals and between terminals to ground. | No breakdown |
| Capacitance | Measure between adjacent terminals at 1 MHz. | 2 picofarads MAXIMUM |
| Temperature Rise (via Current Cycling) | Mate connectors: measure the temperature rise at the rated current after: <ol style="list-style-type: none"> 1) 96 hours (steady state) 2) 240 hours (45 minutes ON and 15 minutes OFF per hour) 3) 96 hours (steady state) | Temperature rise: +30°C MAXIMUM |

| | | | |
|-------------------------------------|--|--|--------------------------------|
| REVISION: T2 | ECM INFORMATION: ECM No: 604532 DATE: 17/09/2018 | TITLE: PRODUCT SPECIFICATION .100 CENTER KK CONNECTORS | SHEET No. 3 of 6 |
| DOCUMENT NUMBER: PS-10-07 | CREATED / REVISED BY: SS06 | CHECKED BY: SS06 | APPROVED BY: ISHWARG |

molex PRODUCT SPECIFICATION

5.2 MECHANICAL REQUIREMENTS

| DESCRIPTION | TEST CONDITION | REQUIREMENT | | |
|--|---|---|-----------------------------------|-----------------------------------|
| Connector Mate and Unmate Forces | Per circuit when mated to an .025 Sq. pin header without friction lock. Mate and unmate connector (male to female) at a rate of 25 ± 6 mm (1 ± ¼ inch) per minute. | 4.9 N (1.1 lbf) MAXIMUM insertion force & 0.56 N (0.125 lbf) MINIMUM withdrawal force | | |
| Connector Mate and Unmate Forces 46856 series only | Per circuit when mated to a .093 thick PCB Mate and unmate connector at a rate of 25 ± 6 mm (1 ± ¼ inch) per minute. | 6.67 N (1.5 lbf) MAXIMUM insertion force & 0.56 N (0.125 lbf) MINIMUM withdrawal force | | |
| Terminal Retention Force (in Housing) | Axial pullout force on the terminal in the housing at a rate of 25 ± 6 mm (1 ± ¼ inch) per minute. (Forces will change with platings and materials.) | 17.8 N (4.0 lbf) MINIMUM withdrawal force | | |
| Terminal Insertion Force (into Housing) | Apply an axial insertion force on the terminal at a rate of 25 ± 6 mm (1 ± ¼ inch) per minute. (Forces will change with platings and materials.) | 11.12 N (2.5 lbf) MAXIMUM insertion force | | |
| Durability | Mate connectors up to 25 cycles at a maximum rate of 10 cycles per minute prior to Environmental Tests. | 10 milliohms MAXIMUM (change from initial) | | |
| Vibration (Sine) | Mate connectors and vibrate per EIA 364-28, test condition I. | 10 milliohms MAXIMUM (change from initial) & Discontinuity < 1 microsecond | | |
| Shock (Mechanical) | Mate connectors and shock at 50 g's with ½ sine wave (11 milliseconds) shocks in the ±X, ±Y, ±Z axes (18 shocks total). | 10 milliohms MAXIMUM (change from initial) & Discontinuity < 1 microsecond | | |
| Wire Pullout Force (Axial) | Apply an axial pullout force on the wire at a rate of 25 ± 6 mm (1 ± ¼ inch) per minute. (For maximum performance use Molex application tooling with stranded tinned copper wire) | Wire pullout force depends on crimp tooling. See relevant Molex Application Tooling Specification for requirements. | | |
| Normal Force | Apply a perpendicular force. | 2.94 N (300 grams) average | | |
| Kinked PC Pin Insertion Force (into PCB Hole) | Apply an axial insertion force on pins at a rate of 25 ± 6 mm (1 ± ¼ inch) per minute. | Number of kinked pins | Maximum Insertion force (per pin) | Average Insertion force (per pin) |
| | | 2 | 44.0 N (9.9 lbf) | 15.1N (3.4 lbf) |
| | | 4 | 21.4 N (4.8 lbf) | 9.8 N (2.2 lbf) |
| | | 6 | 18.2 N (4.1 lbf) | 4.9 N (1.1 lbf) |

| | | | |
|------------------|--|--|----------------|
| REVISION: | ECM INFORMATION: | TITLE: | SHEET No. |
| T2 | ECM No: 604532 DATE: 17/09/2018 | PRODUCT SPECIFICATION .100 CENTER KK CONNECTORS | 4 of 6 |
| DOCUMENT NUMBER: | CREATED / REVISED BY: | CHECKED BY: | APPROVED BY: |
| PS-10-07 | SS06 | SS06 | ISHWARG |

molex PRODUCT SPECIFICATION

5.3 ENVIRONMENTAL REQUIREMENTS

| DESCRIPTION | TEST CONDITION | REQUIREMENT | | | | | | | | | | |
|----------------------------|--|--|--------------------|-----------|----|---------|-----------|------------|----|---------|-----------|---|
| Shock (Thermal) | Mate connectors; expose to 5 cycles of: <table border="1"> <thead> <tr> <th>Temperature °C</th> <th>Duration (Minutes)</th> </tr> </thead> <tbody> <tr> <td>-40 +0/-3</td> <td>30</td> </tr> <tr> <td>+25 ±10</td> <td>5 MAXIMUM</td> </tr> <tr> <td>+105 +3/-0</td> <td>30</td> </tr> <tr> <td>+25 ±10</td> <td>5 MAXIMUM</td> </tr> </tbody> </table> | Temperature °C | Duration (Minutes) | -40 +0/-3 | 30 | +25 ±10 | 5 MAXIMUM | +105 +3/-0 | 30 | +25 ±10 | 5 MAXIMUM | 10 milliohms MAXIMUM (change from initial) & Visual: No Damage |
| Temperature °C | Duration (Minutes) | | | | | | | | | | | |
| -40 +0/-3 | 30 | | | | | | | | | | | |
| +25 ±10 | 5 MAXIMUM | | | | | | | | | | | |
| +105 +3/-0 | 30 | | | | | | | | | | | |
| +25 ±10 | 5 MAXIMUM | | | | | | | | | | | |
| Thermal Aging | Mate connectors; expose to: 96 hours at 105 ± 2°C | 10 milliohms MAXIMUM (change from initial) & Visual: No Damage | | | | | | | | | | |
| Humidity (Steady State) | Mate connectors: expose to a temperature of 40 ± 2°C with a relative humidity of 90-95% for 96 hours. Note: Remove surface moisture and air dry for 1 hour prior to measurements. | 10 milliohms MAXIMUM (change from initial) & Dielectric Withstanding Voltage: No Breakdown at 500 VAC & Insulation Resistance: 1000 Megohms MINIMUM & Visual: No Damage | | | | | | | | | | |
| Humidity (Cyclic) | Mate connectors: cycle per EIA-364-31: 24 cycles at temperature 25 ± 3°C at 80 ± 5% relative humidity and 65 ± 3°C at 50 ± 5% relative humidity; dwell time of 1.0 hour; ramp time of 0.5 hours. {Note: Remove surface moisture and air dry for 1 hour prior to measurements.} | 10 milliohms MAXIMUM (change from initial) & Dielectric Withstanding Voltage: No Breakdown at 500 VAC & Insulation Resistance: 1000 Megohms MINIMUM & Visual: No Damage | | | | | | | | | | |
| Solderability | Per SMES-152 | Solder coverage: 95% MINIMUM (per SMES-152) | | | | | | | | | | |

| | | | |
|-------------------------------------|--|--|--------------------------------|
| REVISION: T2 | ECM INFORMATION: ECM No: 604532 DATE: 17/09/2018 | TITLE: PRODUCT SPECIFICATION .100 CENTER KK CONNECTORS | SHEET No. 5 of 6 |
| DOCUMENT NUMBER: PS-10-07 | CREATED / REVISED BY: SS06 | CHECKED BY: SS06 | APPROVED BY: ISHWARG |

molex PRODUCT SPECIFICATION

5.3 ENVIRONMENTAL REQUIREMENTS

| DESCRIPTION | TEST CONDITION | REQUIREMENT |
|--|---|---|
| Solder Resistance | Dip connector terminal tails in solder: Solder Duration: 5 ± 0.5 seconds; Solder Temperature: $230 \pm 5^\circ\text{C}$ | Visual: No Damage to insulator material |
| Cold Resistance | Mate connectors: Duration: 96 hours; Temperature: $-40 \pm 3^\circ\text{C}$ | 10 milliohms MAXIMUM (change from initial) & Visual: No Damage |
| Corrosive Atmosphere: Flowing Mixed Gas (FMG) | Test per EIA-364-65, Class II, Exposure to gasses for 4 days, unmated. | 10 milliohms MAXIMUM (change from initial) & Visual: No Damage |

6.0 PACKAGING

Parts shall be packaged to protect against damage during handling, transit and storage.

7.0 GAGES AND FIXTURES

8.0 OTHER

| | | | |
|-------------------------------------|--|--|--------------------------------|
| REVISION: T2 | ECM INFORMATION: ECM No: 604532 DATE: 17/09/2018 | TITLE: PRODUCT SPECIFICATION .100 CENTER KK CONNECTORS | SHEET No. 6 of 6 |
| DOCUMENT NUMBER: PS-10-07 | CREATED / REVISED BY: SS06 | CHECKED BY: SS06 | APPROVED BY: ISHWARG |