

Molex 39-53-2034 PDF

深圳创唯电子有限公司

<http://www.molex-connect.com>

1. 製品名称／PRODUCT NAME : 1.25 FFC CONNECTOR ZIF.
 製品番号／PART NUMBER : 5 5 9 7 - N A P B 7 F
 (Nは極数を示す)
 (N IS CIRCUITS SIZE)

2. 標準梱包数／STANDARD PACKAGING QUANTITY

極 数 CKT. SIZE	プラスチックトレイ(10列) PLASTIC TRAY (10 ROWS)	内装カートン PRIMARY CARTON		外装カートン SHIPPING CARTON
	1トレイ製品数 QTY. IN ONE TRAY	トレイ枚数 NUMBER OF TRAYS	製品数 QUANTITY	製品数(内装カートン×4) QUANTITY (PRIMARY CARTON X4)
3	300	6	1,800	7,200
4	250	6	1,500	6,000
5	250	6	1,500	6,000
6	200	6	1,200	4,800
7	200	6	1,200	4,800
8	200	6	1,200	4,800
9	150	6	900	3,600
10	150	6	900	3,600
11	150	6	900	3,600
12	150	6	900	3,600
13	100	6	600	2,400
14	100	6	600	2,400
15	100	6	600	2,400
16	100	6	600	2,400

REV.	E									
SHEET	1~3									
REVISE ON PC ONLY					TITLE:					
E	REVISED J2015-1189 2015/03/18 Y.TOKUZONO				5 5 9 7 - N A P B 7 F 梱包仕様書 SALES PACKAGING SPEC. FOR 5597-NAPB7F					
	THIS DOCUMENT CONTAINS INFORMATION THAT IS PROPRIETARY TO MOLEX INC. AND SHOULD NOT BE USED WITHOUT WRITTEN PERMISSION									
REV.	DESCRIPTION				WRITTEN BY: T.HARUYAMA	CHECKED BY: M.ENOMOTO	APPROVED BY: M.ENOMOTO	DATE: YR/MO/DAY 2001/09/06		
DESIGN CONTROL J					STATUS					
DOCUMENT NUMBER SPK-5597-003								FILE NAME SPK5597003.docx	SHEET 1 OF 3	

極 数 CKT. SIZE	プラスチックトレイ(10列) PLASTIC TRAY (10 ROWS)	内装カートン PRIMARY CARTON		外装カートン SHIPPING CARTON
	1トレイ製品数 QTY. IN ONE TRAY	トレイ枚数 NUMBER OF TRAYS	製品数 QUANTITY	製品数(内装カートン×4) QUANTITY (PRIMARY CARTON X4)
17	100	6	600	2,400
18	100	6	600	2,400
19	100	6	600	2,400
20	100	6	600	2,400
21	100	6	600	2,400
22	90	5	450	1,800
23	90	5	450	1,800
24	80	5	400	1,600
25	80	5	400	1,600
26	80	5	400	1,600
27	80	5	400	1,600
28	70	5	350	1,400
29	70	5	350	1,400
30	70	5	350	1,400
31	70	5	350	1,400
32	70	5	350	1,400
34	60	5	300	1,200
35	60	5	300	1,200

REVISE ON PC ONLY		TITLE:	
E	SEE SHEET 1 OF 3	5 5 9 7 - N A P B 7 F 梱包仕様書 SALES PACKAGING SPEC. FOR 5597-NAPB7F	
	REV.	DESCRIPTION	THIS DOCUMENT CONTAINS INFORMATION THAT IS PROPRIETARY TO MOLEX INC. AND SHOULD NOT BE USED WITHOUT WRITTEN PERMISSION
DOCUMENT NUMBER SPK-5597-003		FILE NAME SPK5597003.docx	SHEET 2 OF 3

3. カートン外形参考寸法 / CARTON OUTER DIMENSIONS (REFERENCE PURPOSE ONLY) 単位 / UNIT: mm

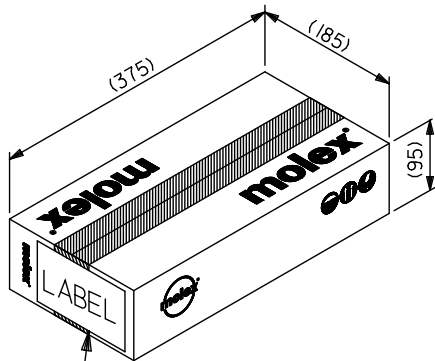

現品票
PART IDENTIFICATION LABEL

(製品型番, 数量, ロットNO. 表示)
INDICATION OF PART No., QUANTITY, LOT No.

内装カートン
PRIMARY CARTON

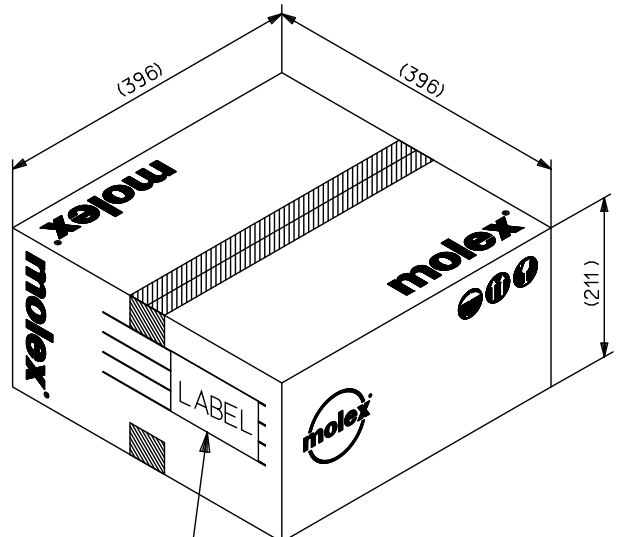

カートンラベル
CARTON LABEL

(製品型番, 数量, ロットNO. 表示)
INDICATION OF PART No., QUANTITY, LOT No.

外装カートン
SHIPPING CARTON

REVISE ON PC ONLY		TITLE:	
E	SEE SHEET 1 OF 3	5 5 9 7 - N A P B 7 F 梱包仕様書 SALES PACKAGING SPEC. FOR 5597-NAPB7F	
	REV.	DESCRIPTION	THIS DOCUMENT CONTAINS INFORMATION THAT IS PROPRIETARY TO MOLEX INC. AND SHOULD NOT BE USED WITHOUT WRITTEN PERMISSION
DOCUMENT NUMBER SPK-5597-003		FILE NAME SPK5597003.docx	SHEET 3 OF 3
EN-037(2013-04 rev.1)			

【1. 適用範囲 SCOPE】

本仕様書は、_____ 殿 に納入する。

1. 25mm ピッチ FFC/FPC用コネクタ について規定する。

This specification covers the 1.25mm PITCH FFC/FPC CONNECTOR series.

【2. 製品名称及び型番 PRODUCT NAME AND PART NUMBER】

製品名称 Product Name	製品型番 Material Number
ハウジングアッセンブリ Housing Assembly	無鉛 LEAD FREE 5597-NAPB7F
ハウジングアッセンブリ Housing Assembly	無鉛 LEAD FREE 5597-NCPB7F
5597-NCPB7F スティック梱包 Stick Package for 5597-NCPB7F	無鉛 LEAD FREE 5597-NCPB7F-ST

N : 図面参照 Refer to the drawings.

【3. 定格 RATINGS】

項目 Item	規格 Standard
最大許容電圧 Rated Voltage (MAXIMUM)	200 V
最大許容電流 Rated Current (MAXIMUM)	1 A
使用温度範囲 Ambient Temperature Range	-20°C ~ +80°C ^{*1}

*1 : 通電による温度上昇分を含む。Including terminal temperature rise.

REV.	A	B	C					
SHEET	1-12	1-12	1-12					
REVISE ON PC ONLY				TITLE:				
C	変更 REVISED J2016-0714 '16/01/12 YMIZUNO02			1.25mm PITCH FFC / FPC CONNECTOR ZIF				
				-LEAD FREE- 製品仕様書				
THIS DOCUMENT CONTAINS INFORMATION THAT IS PROPRIETARY TO MOLEX ELECTRONIC TECHNOLOGIES, LLC AND SHOULD NOT BE USED WITHOUT WRITTEN PERMISSION								
REV.	DESCRIPTION			WRITTEN BY:	CHECKED BY:	APPROVED BY:	DATE: YR/MO/DAY	
	DESIGN CONTROL J			STATUS	N.AIDA	T.TOJO	M.SASAO	
DOCUMENT NUMBER PS-5597-004							FILE NAME PS5597004.docx	SHEET 1 OF 12
EN-037(2015-11 rev.1)								

【4. 性能 PERFORMANCE】

4-1. 電気的性能 Electrical Performance

項目 Item	条件 Test Condition	規格 Requirement
4-1-1 接触抵抗 Contact Resistance	適合FFC/FPCを嵌合させ、開放電圧 20mV 以下、短絡電流 10mA にて測定する。 (JIS C5402 5.4) Mate applicable FFC/FPC, measure by dry circuit, 20mV MAXIMUM, 10mA. (JIS C5402 5.4)	20 milliohm MAXIMUM
4-1-2 絶縁抵抗 Insulation Resistance	適合FFC/FPCを嵌合させ、隣接するターミナル間、ターミナル、アース間に、DC 500Vを印加し測定する。(JIS C5402 5.2/MIL-STD-202 試験法 302) Mate applicable FFC/FPC and apply 500V DC between adjacent terminal or ground. (JIS C5402 5.2/MIL-STD-202 Method 302)	500 megohm MINIMUM
4-1-3 耐電圧 Dielectric Strength	適合FFC/FPCを嵌合させ、隣接するターミナル間及びターミナル、アース間に、AC 500V (実効値) を1分間印加する。 (JIS C5402 5.1/MIL-STD-202 試験法 301) Mate applicable FFC/FPC, apply 500V AC (rms) for 1 minute between adjacent terminal or ground. (JIS C5402 5.1/MIL-STD-202 Method 301)	異常なきこと No Breakdown

4-2. 機械的性能 Mechanical Performance

項目 Item	条件 Test Condition	規格 Requirement
4-2-1 アクチュエータ挿抜力 Actuator Insertion/ Withdrawal Force	適合FFC/FPCを嵌合させ、アクチュエータを毎分 25±3 mmの速さで挿入、抜去を行う。 Mate applicable FFC/FPC and Insert and withdraw actuator at the speed rate of 25±3 mm per minute.	第6項参照 Refer to paragraph 6
4-2-2 FFC/FPC保持力 FFC/FPC Retention Force	アクチュエータ挿入状態にて、毎分 25±3 mmの速さでFFC/FPCを引き抜く。 Insert the actuator, pull the FFC/FPC at the speed rate of 25±3 mm per minute.	第7項参照 Refer to paragraph 7
4-2-3 端子保持力 Terminal/Housing Retention Force	各端子を、毎分 25±3 mm の速さで引き抜く。 Apply axial pull out force at the speed rate of 25±3 mm per minute on the terminal assembled in the housing.	5.9 N {0.6kgf} MINIMUM
4-2-4 端子強度 Terminal Strength	全ての方向に1分間 4.9N(500gf)の力を加える。 Apply 4.9N(500gf) in each X.Y.Z. axes for 1 minute.	割れ、折れのないこと No Damage

REVISE ON PC ONLY		TITLE:
C	SEE SHEET 1 OF 12	1.25mm PITCH FFC / FPC CONNECTOR ZIF
		-LEAD FREE- 製品仕様書
REV.	DESCRIPTION	THIS DOCUMENT CONTAINS INFORMATION THAT IS PROPRIETARY TO MOLEX ELECTRONIC TECHNOLOGIES, LLC AND SHOULD NOT BE USED WITHOUT WRITTEN PERMISSION

DOCUMENT NUMBER
PS-5597-004

FILE NAME SHEET
PS5597004.docx 2 OF 12

4-3. その他 Environmental Performance and Others

項目 Item		条件 Test Condition	規格 Requirement	
4-3-1	アクチュエータ 繰り返し動作 Repeated Actuator Insertion / Withdrawal	無通電状態にて、1分間に10回以下の速さで挿入、 抜去を30回繰り返す。 Insert and withdraw actuator up to 30 cycles at the speed rate of less than 10 cycles per minute.	接触抵抗 Contact Resistance	40 milliohm MAXIMUM
		4-3-2 項から4-3-13 項までのテスト後、 アクチュエータを1回動作させる。 After completion of item 4-3-2~4-3-13 test, Insert and extract actuator up to 1 cycle.	外 観 Appearance	異常なきこと No Damage
4-3-2	温度上昇 Temperature Rise	適合FFC/FPCを嵌合させ、最大許容電流を通電 し、コネクタの温度上昇分を測定する。 (UL 498) Mate applicable FFC/FPC, measure the temperature rise of contact when the maximum AC rated current is passed. (UL 498)	温度上昇 Temperature Rise	30 °C MAXIMUM
4-3-3	耐振動性 Vibration	DC 1mA通電状態にて、嵌合軸を含む互いに垂直 な3方向に掃引割合10~55~10Hz/分、全振幅 1.5mmの振動を各2時間加える。 (JIS C60068-2-6/MIL-STD-202試験法 201) Mate applicable FFC/FPC and subject to the following vibration conditions, for a period of 2 hours in each of 3 mutually perpendicular axes, passing DC 1 mA during the test. Amplitude : 1.5 mm P-P Frequency : 10-55-10 Hz Shall be traversed in 1 minute. (JIS C60068-2-6/MIL-STD-202, Method 201)	外 観 Appearance	異常なきこと No Damage
			接触抵抗 Contact Resistance	40 milliohm MAXIMUM
			瞬断 Discontinuity	1.0 microsecond MAXIMUM
4-3-4	耐衝撃性 Shock	DC 1mA通電状態にて、嵌合軸を含む互いに垂直 な6方向に490m/s ² {50G}の衝撃を各3回加える。 (JIS C60068-2-27/MIL-STD-202試験法 213) Mate applicable FFC/FPC and subject to the following shock conditions. 3 times of shocks shall be applied for each 6 directions along 3 mutually perpendicular axes, passing DC 1 mA current during the test. (Total of 18 shocks) Peak value : 490 m/s ² {50 G} (JIS C60068-2-27/MIL-STD-202 Method 213)	外 観 Appearance	異常なきこと No Damage
			接触抵抗 Contact Resistance	40 milliohm MAXIMUM
			瞬断 Discontinuity	1.0 microsecond MAXIMUM

REVISE ON PC ONLY

C

SEE SHEET 1 OF 12

TITLE:

1.25mm PITCH FFC / FPC CONNECTOR ZIF

-LEAD FREE-

製品仕様書

THIS DOCUMENT CONTAINS INFORMATION THAT IS PROPRIETARY TO MOLEX ELECTRONIC TECHNOLOGIES, LLC AND SHOULD NOT BE USED WITHOUT WRITTEN PERMISSION

REV.

DESCRIPTION

DOCUMENT NUMBER
PS-5597-004

FILE NAME
PS5597004.docx

SHEET
3 OF 12

項目 Item		条件 Test Condition	規格 Requirement	
4-3-5	耐熱性 Heat Resistance	適合FFC/FPCを嵌合させ、85±2℃の雰囲気中に96時間放置後取り出し、1～2時間室温に放置する。 (JIS C60068-2-2/MIL-STD-202 試験法 108) Mate applicable FFC/FPC and expose to 85±2℃ for 96 hours. Upon completion of the exposure period, the test specimens shall be conditioned at ambient room conditions for 1 to 2 hours, after which the specified measurements shall be performed. (JIS C60068-2-2/MIL-STD-202 Method 108)	外観 Appearance	異常なきこと No Damage
			接触抵抗 Contact Resistance	40 milliohm MAXIMUM
4-3-6	耐寒性 Cold Resistance	適合FFC/FPCを嵌合させ、-40±2℃の雰囲気中に96時間放置後取り出し、1～2時間室温に放置する。 (JIS C60068-2-1) Mate applicable FFC/FPC and expose to -40±2℃ for 96 hours. Upon completion of the exposure period, the test specimens shall be conditioned at ambient room conditions for 1 to 2 hours, after which the specified measurements shall be performed. (JIS C60068-2-1)	外観 Appearance	異常なきこと No Damage
			接触抵抗 Contact Resistance	40 milliohm MAXIMUM
4-3-7	耐湿性 Humidity	適合FFC/FPCを嵌合させ、40±2℃ 相対湿度 90～95%の雰囲気中に 96時間放置後取り出し、1～2時間室温に放置する。 (JIS C60068-2-3/MIL-STD-202 試験方法103) Mate applicable FFC/FPC and expose to 40±2℃,relative humidity 90 to 95% for 96 hours. Upon completion of the exposure period, the test specimens shall be conditioned at ambient room conditions for 1 to 2 hours, after which the specified measurements shall be performed. (JIS C60068-2-3/MIL-STD-202 Method 103)	外観 Appearance	異常なきこと No Damage
			接触抵抗 Contact Resistance	40 milliohm MAXIMUM
			耐電圧 Dielectric Strength	4-1-3項 満足のこと Must meet 4-1-3
			絶縁抵抗 Insulation Resistance	50 megohm MINIMUM

REVISE ON PC ONLY

C

SEE SHEET 1 OF 12

TITLE:

1.25mm PITCH FFC / FPC CONNECTOR ZIF

-LEAD FREE-

製品仕様書

THIS DOCUMENT CONTAINS INFORMATION THAT IS PROPRIETARY TO MOLEX ELECTRONIC TECHNOLOGIES, LLC AND SHOULD NOT BE USED WITHOUT WRITTEN PERMISSION

REV.

DESCRIPTION

DOCUMENT NUMBER
PS-5597-004

FILE NAME
PS5597004.docx

SHEET
4 OF 12

項目 Item		条件 Test Condition	規格 Requirement	
4-3-8	温度サイクル Temperature Cycling	適合FFC/FPCを嵌合させ、-30±3℃に30分、+85±2℃に30分、これを1サイクルとし、5サイクル繰り返す。但し、温度移行時間は3分以内とする。試験後1~2時間室温に放置する。(JIS C0025) Mate applicable FFC/FPC and subject to the following conditions for 5 cycles. Upon completion of the exposure period, the test specimens shall be conditioned at ambient room conditions for 1 to 2 hours, after which the specified measurements shall be performed. 1 cycle -30±3℃ 30minutes +85±2℃ 30minutes (Transit time shall be within 3 minutes) (JIS C0025)	外 観 Appearance	異常なきこと No Damage
			接触抵抗 Contact Resistance	40 milliohm MAXIMUM
4-3-9	塩水噴霧 Salt Spray	適合FFC/FPCを嵌合させ、35±2℃にて重量比 5±1%の塩水を 48±4時間噴霧し、試験後常温で水洗いした後、室温で乾燥させる。 (JIS C60068-2-11/MIL-STD-202 試験方法101) Mate applicable FFC/FPC and expose to the following salt mist condition. Upon completion of the exposure period, salt deposits shall be removed by a gentle wash or dip in running water, after which the specified measurements shall be performed. NaCl solution Concentration : 5±1% Spray time : 48±4 hours Ambient temperature : 35±2℃ (JIS C60068-2-11/MIL-STD-202 Method 101)	外 観 Appearance	異常なきこと No Damage
			接触抵抗 Contact Resistance	40 milliohm MAXIMUM
4-3-10	亜硫酸ガス SO ₂ Gas	適合FFC/FPCを嵌合させ、40±2℃にて50±5ppmの亜硫酸ガス中に24時間放置する。 Mate applicable FFC/FPC and expose them to the following SO ₂ gas atmosphere. Temperature 40±2℃ Gas Density 50±5ppm Duration 24 hours	外 観 Appearance	異常なきこと No Damage
			接触抵抗 Contact Resistance	40 milliohm MAXIMUM
4-3-11	耐アンモニア性 NH ₃ Gas	適合FFC/FPCを嵌合させ、濃度28%のアンモニア水を入れた容器中に40分間放置する。 (1Lに対して25mLの割合) Mate applicable FFC/FPC and 40 minutes exposure to NH ₃ gas evaporating from 28% Ammonia solution.	外 観 Appearance	異常なきこと No Damage
			接触抵抗 Contact Resistance	40 milliohm MAXIMUM

REVISE ON PC ONLY

C

SEE SHEET 1 OF 12

TITLE:

1.25mm PITCH FFC / FPC CONNECTOR ZIF

-LEAD FREE-

製品仕様書

THIS DOCUMENT CONTAINS INFORMATION THAT IS PROPRIETARY TO MOLEX ELECTRONIC TECHNOLOGIES, LLC AND SHOULD NOT BE USED WITHOUT WRITTEN PERMISSION

REV.

DESCRIPTION

DOCUMENT NUMBER

PS-5597-004

FILE NAME

PS5597004.docx

SHEET

5 OF 12

項目 Item		条件 Test Condition	規格 Requirement	
4-3-12	半田付け性 Solder Ability	端子をフラックスに浸し、本体の取付け基準面より1.2mmまで、245±3°Cの半田に3±0.5秒浸す。 Soldering time : 3±0.5 seconds Solder temperature : 245±3°C	濡れ性 Solder Wetting	浸漬面積 75%以上 75% of immersed area must show no voids, pin holes.
4-3-13	半田耐熱性 Resistance to Soldering Heat	(ディップの場合) Soldering bath method 端子を本体の取付け基準面より1.2mmまで、260±5°Cの半田に5±0.5秒浸す。 Soldering time : 5±0.5 seconds Solder temperature : 260±5°C	外観 Appearance	端子ガタ、割れ等 異状無き事 No Damage
		(手半田時) Soldering iron method 370~400°Cの半田ゴテにて最大5秒加熱する。但し、端ピンに異常な加圧のないこと。 Solder Time : 5 sec MAX. Solder Temperature: 370~400°C However, without too much pressure to the terminal pin.		

() : 参考規格 Reference Standard
{ } : 参考単位 Reference Unit

【5. 外観形状、寸法及び材質 PRODUCT SHAPE, DIMENSIONS AND MATERIALS】

図面参照 Refer to the drawing.

REVISE ON PC ONLY		TITLE:	
C	SEE SHEET 1 OF 12	1.25mm PITCH FFC / FPC CONNECTOR ZIF	
	REV.	DESCRIPTION	-LEAD FREE- 製品仕様書
DOCUMENT NUMBER PS-5597-004		THIS DOCUMENT CONTAINS INFORMATION THAT IS PROPRIETARY TO MOLEX ELECTRONIC TECHNOLOGIES, LLC AND SHOULD NOT BE USED WITHOUT WRITTEN PERMISSION	
		FILE NAME PS5597004.docx	SHEET 6 OF 12
EN-037(2015-11 rev.1)			

【 6. アクチュエータ保持力(FFC) ACTUATOR INSERTION/WITHDRAWAL FORCE(FFC)】

極数 Number of Circuit	単位 UNIT	挿入力 (最大値) Insertion Force (MAXIMUM)			抜去力 (最大値) Withdrawal Force (MAXIMUM)		
		初回 1st	6回目 6th	30回目 30th	初回 1st	6回目 6th	30回目 30th
3	N {kgf}	27.4 {2.8}	26.4 {2.7}	26.4 {2.7}	28.4 {2.9}	27.4 {2.8}	27.4 {2.8}
4	N {kgf}	29.4 {3.0}	28.4 {2.9}	28.4 {2.9}	30.3 {3.1}	29.4 {3.0}	29.4 {3.0}
5	N {kgf}	30.3 {3.1}	29.4 {3.0}	29.4 {3.0}	31.3 {3.2}	30.3 {3.1}	30.3 {3.1}
6	N {kgf}	32.3 {3.3}	30.3 {3.1}	30.3 {3.1}	33.3 {3.4}	31.3 {3.2}	31.3 {3.2}
7	N {kgf}	33.3 {3.4}	31.3 {3.2}	31.3 {3.2}	34.3 {3.5}	32.3 {3.3}	32.3 {3.3}
8	N {kgf}	35.2 {3.6}	33.3 {3.4}	33.3 {3.4}	36.2 {3.7}	34.3 {3.5}	34.3 {3.5}
9	N {kgf}	36.2 {3.7}	34.3 {3.5}	34.3 {3.5}	37.2 {3.8}	35.2 {3.6}	35.2 {3.6}
10	N {kgf}	38.2 {3.9}	36.2 {3.7}	36.2 {3.7}	39.2 {4.0}	37.2 {3.8}	37.2 {3.8}
11	N {kgf}	39.2 {4.0}	37.2 {3.8}	37.2 {3.8}	40.1 {4.1}	38.2 {3.9}	38.2 {3.9}
12	N {kgf}	41.1 {4.2}	39.2 {4.0}	39.2 {4.0}	42.1 {4.3}	40.1 {4.1}	40.1 {4.1}
13	N {kgf}	42.1 {4.3}	40.1 {4.1}	40.1 {4.1}	43.1 {4.4}	41.1 {4.2}	41.1 {4.2}
14	N {kgf}	43.1 {4.4}	41.1 {4.2}	41.1 {4.2}	44.1 {4.5}	42.1 {4.3}	42.1 {4.3}
15	N {kgf}	45.0 {4.6}	42.1 {4.3}	42.1 {4.3}	46.0 {4.7}	43.1 {4.4}	43.1 {4.4}
16	N {kgf}	46.0 {4.7}	43.1 {4.4}	43.1 {4.4}	47.0 {4.8}	44.1 {4.5}	44.1 {4.5}
17	N {kgf}	48.0 {4.9}	45.0 {4.6}	45.0 {4.6}	49.0 {5.0}	46.0 {4.7}	46.0 {4.7}
18	N {kgf}	49.0 {5.0}	46.0 {4.7}	46.0 {4.7}	49.9 {5.1}	47.0 {4.8}	47.0 {4.8}

REVISE ON PC ONLY

C

SEE SHEET 1 OF 12

TITLE:

1.25mm PITCH FFC / FPC CONNECTOR ZIF

-LEAD FREE-

製品仕様書

THIS DOCUMENT CONTAINS INFORMATION THAT IS PROPRIETARY TO MOLEX ELECTRONIC TECHNOLOGIES, LLC AND SHOULD NOT BE USED WITHOUT WRITTEN PERMISSION

REV.

DESCRIPTION

DOCUMENT NUMBER

PS-5597-004

FILE NAME

PS5597004.docx

SHEET

7 OF 12

極数 Number of Circuit	単位 UNIT	挿入力 (最大値) Insertion Force (MAXIMUM)			抜去力 (最大値) Withdrawal Force (MAXIMUM)		
		初回 1st	6回目 6th	30回目 30th	初回 1st	6回目 6th	30回目 30th
19	N {kgf}	50.9 {5.2}	47.0 {4.8}	47.0 {4.8}	51.9 {5.3}	48.0 {4.9}	48.0 {4.9}
20	N {kgf}	51.9 {5.3}	48.0 {4.9}	48.0 {4.9}	52.9 {5.4}	49.0 {5.0}	49.0 {5.0}
21	N {kgf}	53.9 {5.5}	49.9 {5.1}	49.9 {5.1}	54.8 {5.6}	50.9 {5.2}	50.9 {5.2}
22	N {kgf}	54.8 {5.6}	50.9 {5.2}	50.9 {5.2}	55.8 {5.7}	51.9 {5.3}	51.9 {5.3}
23	N {kgf}	56.8 {5.8}	51.9 {5.3}	51.9 {5.3}	57.8 {5.9}	52.9 {5.4}	52.9 {5.4}
24	N {kgf}	57.8 {5.9}	52.9 {5.4}	52.9 {5.4}	58.8 {6.0}	53.9 {5.5}	53.9 {5.5}
25	N {kgf}	59.7 {6.1}	54.8 {5.6}	54.8 {5.6}	60.7 {6.2}	55.8 {5.7}	55.8 {5.7}
26	N {kgf}	60.7 {6.2}	55.8 {5.7}	55.8 {5.7}	61.7 {6.3}	56.8 {5.8}	56.8 {5.8}
27	N {kgf}	62.7 {6.4}	56.8 {5.8}	56.8 {5.8}	63.7 {6.5}	57.8 {5.9}	57.8 {5.9}
28	N {kgf}	63.7 {6.5}	57.8 {5.9}	57.8 {5.9}	64.6 {6.6}	58.8 {6.0}	58.8 {6.0}
29	N {kgf}	65.6 {6.7}	59.7 {6.1}	59.7 {6.1}	66.6 {6.8}	60.7 {6.2}	60.7 {6.2}
30	N {kgf}	66.6 {6.8}	60.7 {6.2}	60.7 {6.2}	67.6 {6.9}	61.7 {6.3}	61.7 {6.3}
31	N {kgf}	68.6 {7.0}	62.7 {6.4}	62.7 {6.4}	69.5 {7.1}	63.7 {6.5}	63.7 {6.5}
32	N {kgf}	69.5 {7.1}	63.7 {6.5}	63.7 {6.5}	70.5 {7.2}	64.6 {6.6}	64.6 {6.6}
34	N {kgf}	72.5 {7.4}	66.6 {6.8}	66.6 {6.8}	73.5 {7.5}	66.6 {6.8}	66.6 {6.8}

REVISE ON PC ONLY		TITLE: 1.25mm PITCH FFC / FPC CONNECTOR ZIF	
C	SEE SHEET 1 OF 12	-LEAD FREE- 製品仕様書	
	REV. DESCRIPTION	THIS DOCUMENT CONTAINS INFORMATION THAT IS PROPRIETARY TO MOLEX ELECTRONIC TECHNOLOGIES, LLC AND SHOULD NOT BE USED WITHOUT WRITTEN PERMISSION	
DOCUMENT NUMBER PS-5597-004		FILE NAME PS5597004.docx	SHEET 8 OF 12
EN-037(2015-11 rev.1)			

【6. アクチュエータ保持力(FPC) ACTUATOR INSERTION/WITHDRAWAL FORCE(FPC)】

極数 Number of Circuit	単位 UNIT	挿入力 (最大値) Insertion Force (MAXIMUM)			抜去力 (最大値) Withdrawal Force (MAXIMUM)		
		初回 1st	6回目 6th	30回目 30th	初回 1st	6回目 6th	30回目 30th
3	N {kgf}	23.5 {2.4}	22.5 {2.3}	22.5 {2.3}	32.3 {3.3}	31.3 {3.2}	31.3 {3.2}
4	N {kgf}	25.4 {2.6}	24.5 {2.5}	24.5 {2.5}	34.3 {3.5}	33.3 {3.4}	33.3 {3.4}
5	N {kgf}	26.4 {2.7}	25.4 {2.6}	25.4 {2.6}	35.2 {3.6}	34.3 {3.5}	34.3 {3.5}
6	N {kgf}	28.4 {2.9}	26.4 {2.7}	26.4 {2.7}	37.2 {3.8}	35.2 {3.6}	35.2 {3.6}
7	N {kgf}	29.4 {3.0}	27.4 {2.8}	27.4 {2.8}	38.2 {3.9}	36.2 {3.7}	36.2 {3.7}
8	N {kgf}	31.3 {3.2}	29.4 {3.0}	29.4 {3.0}	40.1 {4.1}	37.2 {3.8}	37.2 {3.8}
9	N {kgf}	32.3 {3.3}	30.3 {3.1}	30.3 {3.1}	41.1 {4.2}	38.2 {3.9}	38.2 {3.9}
10	N {kgf}	34.3 {3.5}	32.3 {3.3}	32.3 {3.3}	43.1 {4.4}	39.2 {4.0}	39.2 {4.0}
11	N {kgf}	29.4 {3.0}	27.4 {2.8}	27.4 {2.8}	39.2 {4.0}	37.2 {3.8}	37.2 {3.8}
12	N {kgf}	30.3 {3.1}	28.4 {2.9}	28.4 {2.9}	40.1 {4.1}	38.2 {3.9}	38.2 {3.9}
13	N {kgf}	31.3 {3.2}	29.4 {3.0}	29.4 {3.0}	41.1 {4.2}	39.2 {4.0}	39.2 {4.0}
14	N {kgf}	32.3 {3.3}	30.3 {3.1}	30.3 {3.1}	42.1 {4.3}	40.1 {4.1}	40.1 {4.1}
15	N {kgf}	34.3 {3.5}	31.3 {3.2}	31.3 {3.2}	44.1 {4.5}	41.1 {4.2}	41.1 {4.2}
16	N {kgf}	35.2 {3.6}	32.3 {3.3}	32.3 {3.3}	45.0 {4.6}	42.1 {4.3}	42.1 {4.3}
17	N {kgf}	36.2 {3.7}	33.3 {3.4}	33.3 {3.4}	46.0 {4.7}	43.1 {4.4}	43.1 {4.4}
18	N {kgf}	37.2 {3.8}	34.3 {3.5}	34.3 {3.5}	47.0 {4.8}	44.1 {4.5}	44.1 {4.5}

REVISE ON PC ONLY

C

SEE SHEET 1 OF 12

TITLE:

1.25mm PITCH FFC / FPC CONNECTOR ZIF

-LEAD FREE-

製品仕様書

THIS DOCUMENT CONTAINS INFORMATION THAT IS PROPRIETARY TO MOLEX ELECTRONIC TECHNOLOGIES, LLC AND SHOULD NOT BE USED WITHOUT WRITTEN PERMISSION

REV.

DESCRIPTION

DOCUMENT NUMBER

PS-5597-004

FILE NAME

PS5597004.docx

SHEET

9 OF 12

極数 Number of Circuit	単位 UNIT	挿入力 (最大値) Insertion Force (MAXIMUM)			抜去力 (最大値) Withdrawal Force (MAXIMUM)		
		初回 1st	6回目 6th	30回目 30th	初回 1st	6回目 6th	30回目 30th
19	N {kgf}	39.2 {4.0}	35.2 {3.6}	35.2 {3.6}	49.0 {5.0}	45.0 {4.6}	45.0 {4.6}
20	N {kgf}	40.1 {4.1}	36.2 {3.7}	36.2 {3.7}	49.9 {5.1}	46.0 {4.7}	46.0 {4.7}
21	N {kgf}	41.1 {4.2}	37.2 {3.8}	37.2 {3.8}	50.9 {5.2}	47.0 {4.8}	47.0 {4.8}
22	N {kgf}	42.1 {4.3}	38.2 {3.9}	38.2 {3.9}	51.9 {5.3}	48.0 {4.9}	48.0 {4.9}
23	N {kgf}	44.1 {4.5}	39.2 {4.0}	39.2 {4.0}	53.9 {5.5}	49.0 {5.0}	49.0 {5.0}
24	N {kgf}	45.0 {4.6}	40.1 {4.1}	40.1 {4.1}	54.8 {5.6}	49.9 {5.1}	49.9 {5.1}
25	N {kgf}	46.0 {4.7}	41.1 {4.2}	41.1 {4.2}	55.8 {5.7}	50.9 {5.2}	50.9 {5.2}
26	N {kgf}	47.0 {4.8}	42.1 {4.3}	42.1 {4.3}	56.8 {5.8}	51.9 {5.3}	51.9 {5.3}
27	N {kgf}	49.0 {5.0}	43.1 {4.4}	43.1 {4.4}	58.8 {6.0}	52.9 {5.4}	52.9 {5.4}
28	N {kgf}	49.9 {5.1}	44.1 {4.5}	44.1 {4.5}	59.7 {6.1}	53.9 {5.5}	53.9 {5.5}
29	N {kgf}	50.9 {5.2}	45.0 {4.6}	45.0 {4.6}	60.7 {6.2}	54.8 {5.6}	54.8 {5.6}
30	N {kgf}	51.9 {5.3}	46.0 {4.7}	46.0 {4.7}	61.7 {6.3}	55.8 {5.7}	55.8 {5.7}
31	N {kgf}	53.9 {5.5}	47.0 {4.8}	47.0 {4.8}	63.7 {6.5}	56.8 {5.8}	56.8 {5.8}
32	N {kgf}	54.8 {5.6}	48.0 {4.9}	48.0 {4.9}	64.6 {6.6}	57.8 {5.9}	57.8 {5.9}
34	N {kgf}	56.8 {5.8}	49.9 {5.1}	49.9 {5.1}	66.6 {6.8}	59.7 {6.1}	59.7 {6.1}

REVISE ON PC ONLY		TITLE:	
C	SEE SHEET 1 OF 12	1.25mm PITCH FFC / FPC CONNECTOR ZIF	
		-LEAD FREE- 製品仕様書	
REV.	DESCRIPTION	THIS DOCUMENT CONTAINS INFORMATION THAT IS PROPRIETARY TO MOLEX ELECTRONIC TECHNOLOGIES, LLC AND SHOULD NOT BE USED WITHOUT WRITTEN PERMISSION	
DOCUMENT NUMBER PS-5597-004		FILE NAME PS5597004.docx	SHEET 10 OF 12
EN-037(2015-11 rev.1)			

【7. FFC/FPC保持力 FPC RETENTION FORCE】

極数 Number of Circuit	単位 UNIT	保持力 (最小値) Retention Force (MINIMUM)		極数 Number of Circuit	単位 UNIT	保持力 (最小値) Retention Force (MINIMUM)	
		初回 1st	10回目 10th			初回 1st	10回目 10th
3	N {kgf}	5.4 {0.55}	4.9 {0.50}	19	N {kgf}	10.8 {1.10}	7.9 {0.80}
4	N {kgf}	5.9 {0.60}	4.9 {0.50}	20	N {kgf}	11.3 {1.15}	7.9 {0.80}
5	N {kgf}	6.4 {0.65}	5.4 {0.55}	21	N {kgf}	11.8 {1.20}	8.4 {0.85}
6	N {kgf}	6.9 {0.70}	5.9 {0.60}	22	N {kgf}	12.3 {1.25}	8.9 {0.90}
7	N {kgf}	7.4 {0.75}	6.4 {0.65}	23	N {kgf}	12.8 {1.30}	8.9 {0.90}
8	N {kgf}	7.9 {0.80}	6.9 {0.70}	24	N {kgf}	13.3 {1.35}	9.4 {0.95}
9	N {kgf}	8.4 {0.85}	7.4 {0.75}	25	N {kgf}	13.8 {1.40}	11.8 {1.20}
10	N {kgf}	8.9 {0.90}	7.9 {0.80}	26	N {kgf}	14.3 {1.45}	12.3 {1.25}
11	N {kgf}	6.9 {0.70}	4.9 {0.50}	27	N {kgf}	14.7 {1.50}	12.8 {1.30}
12	N {kgf}	7.4 {0.75}	5.4 {0.55}	28	N {kgf}	15.2 {1.55}	13.3 {1.35}
13	N {kgf}	7.9 {0.80}	5.9 {0.60}	29	N {kgf}	15.7 {1.60}	13.8 {1.40}
14	N {kgf}	8.4 {0.85}	5.9 {0.60}	30	N {kgf}	16.2 {1.65}	14.3 {1.45}
15	N {kgf}	8.9 {0.90}	6.4 {0.65}	31	N {kgf}	16.7 {1.70}	14.7 {1.50}
16	N {kgf}	9.4 {0.95}	6.9 {0.70}	32	N {kgf}	17.2 {1.75}	15.2 {1.55}
17	N {kgf}	9.8 {1.00}	6.9 {0.70}	34	N {kgf}	18.2 {1.85}	16.2 {1.65}
18	N {kgf}	10.3 {1.05}	7.4 {0.75}				

REVISE ON PC ONLY

C

SEE SHEET 1 OF 12

TITLE:

1.25mm PITCH FFC / FPC CONNECTOR ZIF

-LEAD FREE-

製品仕様書

THIS DOCUMENT CONTAINS INFORMATION THAT IS PROPRIETARY TO MOLEX ELECTRONIC TECHNOLOGIES, LLC AND SHOULD NOT BE USED WITHOUT WRITTEN PERMISSION

REV.

DESCRIPTION

DOCUMENT NUMBER
PS-5597-004

FILE NAME
PS5597004.docx

SHEET
11 OF 12

