

Molex 0416710023 PDF

molex[®]

深圳创唯电子有限公司 [http://www.molex-
connect.com](http://www.molex-connect.com)

KK 396 /.156

WIRE-TO-BOARD BOARD-TO-BOARD CONNECTOR SYSTEM

Crimp Terminals	Crimp Housings
	
Series: 2478 , 2578 , 2878 , 2477 , 8818	Series: 2139 , 41695 , 3069

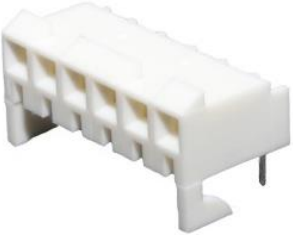
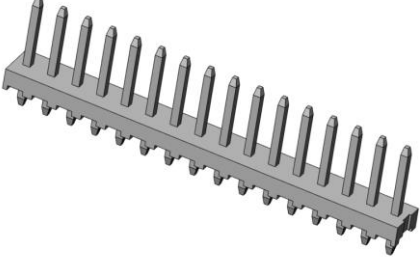



PCB Connector	Vertical Header Without Peg
	
Series: 41815	Series: 41771

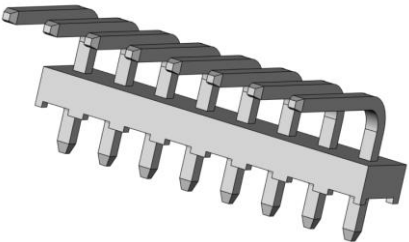

[MOLEX KK 396 WEB PAGE](#)

[TABLE OF CONTENTS](#)

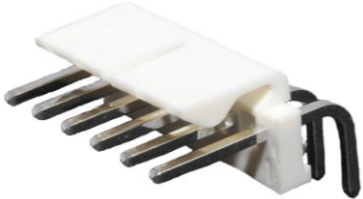
REVISION: T1	ECM INFORMATION: EC No: 617983 DATE: 2019/05/27	TITLE: PRODUCT SPECIFICATION .156 CENTER KK CONNECTORS	SHEET No. 1 of 14
DOCUMENT NUMBER: PS-08-50	DOC TYPE: PS	DOC PART: 001	CREATED / REVISED BY: SS06
	CHECKED BY: ISHWARG	APPROVED BY: ISHWARG	



Right Angle Header Without Peg	Vertical Header with Friction Lock
	
Series: 41772	Series: 41791
Right Angle Header with Friction Lock	Vertical Header With press fit plastic Peg
	
Series: 41792	Series: 42491, 42891



[MOLEX KK 396 WEB PAGE](#)

[TABLE OF CONTENTS](#)

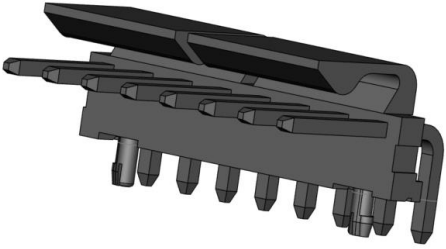
REVISION: T1	ECM INFORMATION: EC No: 617983 DATE: 2019/05/27	TITLE: PRODUCT SPECIFICATION .156 CENTER KK CONNECTORS				SHEET No. 2 of 14
DOCUMENT NUMBER: PS-08-50	DOC TYPE: PS	DOC PART: 001	CREATED / REVISED BY: SS06	CHECKED BY: ISHWARG	APPROVED BY: ISHWARG	

Right Angle Header With press fit plastic Peg	Right Angle Break away Header
	
Series: 42492 , 42892	Series: 41662 , 172173

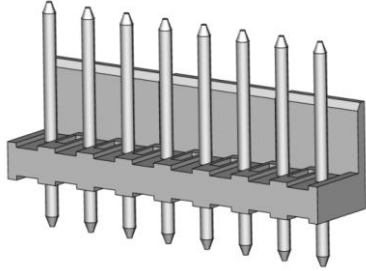
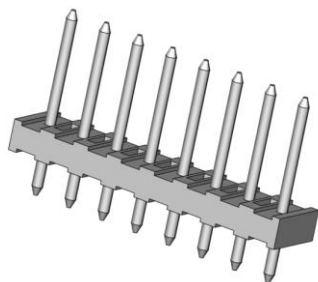

Vertical header with round pin and Polarizing Wall	Vertical header with round pin
	
Series: 3190	Series: 3192



[MOLEX KK 396 WEB PAGE](#)

[TABLE OF CONTENTS](#)

REVISION: T1	ECM INFORMATION: EC No: 617983 DATE: 2019/05/27	TITLE: PRODUCT SPECIFICATION .156 CENTER KK CONNECTORS				SHEET No. 3 of 14
DOCUMENT NUMBER: PS-08-50	DOC TYPE: PS	DOC PART: 001	CREATED / REVISED BY: SS06	CHECKED BY: ISHWARG	APPROVED BY: ISHWARG	

Vertical break away header	Vertical break away header with Friction Lock
	
Series: 41661	Series: 41671

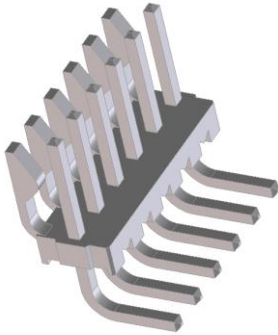
Right angle break away header with Friction Lock

Series: 41672



[MOLEX KK 396 WEB PAGE](#)

[TABLE OF CONTENTS](#)

REVISION: T1	ECM INFORMATION: EC No: 617983 DATE: 2019/05/27	TITLE: PRODUCT SPECIFICATION .156 CENTER KK CONNECTORS	SHEET No. 4 of 14
DOCUMENT NUMBER: PS-08-50	DOC TYPE: PS	DOC PART: 001	CREATED / REVISED BY: SS06
	CHECKED BY: ISHWARG	APPROVED BY: ISHWARG	

1.0	SCOPE	<u>6</u>
2.0	PRODUCT DESCRIPTION	<u>6</u>
2.1	Product Name and Series Numbers	<u>6</u>
2.2	Dimensions, Materials, Plating and Markings	<u>7</u>
2.3	Safety Agency Approvals	<u>7</u>
3.0	APPLICABLE DOCUMENTS AND SPECIFICATIONS	<u>8</u>
3.1	Molex Documents	<u>8</u>
3.2	Industry Documents	<u>8</u>
4.0	ELECTRICAL PERFORMANCE RATINGS	<u>8</u>
4.1	Voltage	<u>8</u>
4.2	Maximum Current Rating	<u>8</u>
4.3	Temperature	<u>9</u>
4.4	Durability	<u>9</u>
5.0	QUALIFICATION	<u>9</u>
6.0	PERFORMANCE	<u>10</u>
6.1	Electrical Performance	<u>10</u>
6.2	Mechanical Performance	<u>11</u>
6.3	Environmental Performance	<u>12</u>
7.0	SOLDER INFORMATION	<u>14</u>
7.1	Solder Process Temperature	<u>14</u>
8.0	PACKAGING	<u>14</u>
9.0	CABLE TIE AND/OR WIRE TWIST LOCATION	<u>14</u>



[MOLEX KK 396 WEB PAGE](#)

[TABLE OF CONTENTS](#)

REVISION: T1	ECM INFORMATION: EC No: 617983 DATE: 2019/05/27	TITLE: PRODUCT SPECIFICATION .156 CENTER KK CONNECTORS	SHEET No. 5 of 14		
DOCUMENT NUMBER: PS-08-50	DOC TYPE: PS	DOC PART: 001	CREATED / REVISED BY: SS06	CHECKED BY: ISHWARG	APPROVED BY: ISHWARG

1.0 SCOPE

This Product Specification covers the 3.96 mm (.156 inch) centerline (pitch) 1.14mm (.045) square pin headers when mated with either printed circuit board (PCB) connectors or connectors terminated with 18 to 26 AWG wire using crimp technology.

2.0 PRODUCT DESCRIPTION

2.1 PRODUCT NAME AND SERIES NUMBER (S)

Description	Series Number
Crimp Terminals	2478, 2578, 2878, 2477, 8818
Crimp Housings	2139, 41695, 3069
PCB Connectors	41815
Vertical Header without Peg	41771
Right angle Header without peg	41772
Vertical Header with Friction Lock	41791
Right Angle Header with Friction Lock	41792
Vertical Header with press fit plastic Peg	42491, 42891
Right Angle Header with press fit plastic Peg	42492, 42892
Vertical Break away Header	41661, 41671
Right Angle Break away Header	41662, 172173
Right angle break away header with Friction Lock	41672
Vertical header with Round Pin with Polarizing Wall	3190
Vertical header with Round Pin without Polarizing Wall	3192

Other products conforming to this specification are noted on the individual drawings.



[MOLEX KK 396 WEB PAGE](#)

[TABLE OF CONTENTS](#)

REVISION: T1	ECM INFORMATION: EC No: 617983 DATE: 2019/05/27	TITLE: PRODUCT SPECIFICATION .156 CENTER KK CONNECTORS	SHEET No. 6 of 14
DOCUMENT NUMBER: PS-08-50	DOC TYPE: PS	DOC PART: 001	CREATED / REVISED BY: SS06
	CHECKED BY: ISHWARG	APPROVED BY: ISHWARG	

2.2 DIMENSIONS, MATERIALS, PLATING AND MARKINGS

Terminal Material: Brass or Phos. Bronze (for Max performance use phos bronze material.)
 Housing: Nylon or Polyester
 Pins: Brass
 For more information on dimensions, materials, and plating see the individual drawings.

Material: RoHS compliant materials.

**Refer to the "Product Environmental Compliance" section in Molex.com to know the individual PN RoHS compliance status*

2.3 SAFETY AGENCY APPROVALS

UL File Number E29179
 CSALR19980

SERIES	Agency Voltage Rating (AC RMS or DC) except as noted		Agency Current Rating (Single Circuit) (Amps)		Agency Temperature Rating (°C)
	UL	CSA	UL	CSA	UL
2139	600	250	-	7	105°C
41661	600	250	-	7	105°C
41662	600	250	-	7	105°C
41671	600	250	-	7	105°C
41672	600	250	-	7	105°C
41695	600	250VAC	-	7	105°C
41771	600	250	-	7	105°C
41772	600	250	-	7	105°C
41791	600	250	-	7	105°C
41792	600	250	-	7	105°C
41815	600	250	-	5	105°C
42491	600	250	-	7	105°C
42492	600	250	-	7	105°C

Other products conforming to this specification are noted on the individual drawings.



[MOLEX KK 396 WEB PAGE](#)

[TABLE OF CONTENTS](#)

REVISION: T1	ECM INFORMATION: EC No: 617983 DATE: 2019/05/27	TITLE: PRODUCT SPECIFICATION .156 CENTER KK CONNECTORS	SHEET No. 7 of 14
DOCUMENT NUMBER: PS-08-50	DOC TYPE: PS	DOC PART: 001	CREATED / REVISED BY: SS06
	CHECKED BY: ISHWARG	APPROVED BY: ISHWARG	

3.0 APPLICABLE DOCUMENTS AND SPECIFICATIONS

3.1 MOLEX DOCUMENTS

See series specific sales drawings and the other sections of this specifications for the necessary referenced documents and specifications.

Cosmetic Specification PS-45499-002

[Molex Quality Crimping Handbook Order No. 63800-0029](#)

[Molex Solderability Specification SMES-152](#)

[Molex Heat Resistance Specification AS-40000-5013](#)

[Molex Moisture Technical Advisory AS-45499-001](#)

[Molex Package Handling Specification 454990100-PK](#)

3.2 INDUSTRY DOCUMENTS

EIA-364-1000.01

UL-1977

CSA STD. C22.2 NO. 182.3-M1987

4.0 ELECTRICAL PERFORMANCE RATINGS

4.1 VOLTAGE*

600 Volts AC (RMS) or 600 Volts DC max.

4.2 MAXIMUM CURRENT RATING

NOTE : current is dependent on connector size, contact material, plating, ambient temperature, printed circuit board characteristics and related factors. Actual current rating is application dependent and should be evaluated for each application

a. For Crimp Terminals- and Applicable Wires

Wire Awg	Amps (Max) With Brass Terminals	Amps (Max) With Phos Bronze Terminals	Wire Insulation Diameter
18	5.00	7.00	See terminal drawings
20	4.75	6.25	See terminal drawings
22	4.50	5.50	See terminal drawings
24	4.25	5.00	See terminal drawings
26	4.00	4.50	See terminal drawings

Note: current ratings are for a single circuit, based on not exceeding 30°C temperature rise



[MOLEX KK 396 WEB PAGE](#)

[TABLE OF CONTENTS](#)

REVISION: T1	ECM INFORMATION: EC No: 617983 DATE: 2019/05/27	TITLE: PRODUCT SPECIFICATION .156 CENTER KK CONNECTORS	SHEET No. 8 of 14
DOCUMENT NUMBER: PS-08-50	DOC TYPE: PS	DOC PART: 001	CREATED / REVISED BY: SS06
	CHECKED BY: ISHWARG	APPROVED BY: ISHWARG	

b. For Printed Circuit Board Connectors

Connector Style	Amps (Max) With Brass Terminals	Amps (Max) With Phos Bronze Terminals
Top Entry	4.50	5.00
Right Angle	4.50	5.00
Bottom Entry	4.00	4.50

Note: current ratings are for a single circuit, based on not exceeding 30°C temperature rise

4.3 TEMPERATURE

	Brass Terminals	Phos Bronze Terminals
Operating Temperature	-40°C to +80°C*	-40°C to +105°C*
Non-Operating Temperature	-40°C to +105°C**	-40°C to +105°C

*including terminal temperature rise. **parts not mated.

4.4 DURABILITY

Tin / Gold plated: 25 mating cycles

As tested in accordance with EIA-364-1000.01 test method (see Sec. 6.2 of this specification).

5.0 QUALIFICATION

Laboratory conditions and sample selection are in accordance with EIA-364-1000.01



[MOLEX KK 396 WEB PAGE](#)

[TABLE OF CONTENTS](#)

REVISION: T1	ECM INFORMATION: EC No: 617983 DATE: 2019/05/27	TITLE: PRODUCT SPECIFICATION .156 CENTER KK CONNECTORS	SHEET No. 9 of 14		
DOCUMENT NUMBER: PS-08-50	DOC TYPE: PS	DOC PART: 001	CREATED / REVISED BY: SS06	CHECKED BY: ISHWARG	APPROVED BY: ISHWARG

6.0 PERFORMANCE

6.1 ELECTRICAL PERFORMANCE

ITEM NO.	ITEM	TEST CONDITION	REQUIREMENT
1	Contact Resistance (Low Level)	Mate connectors: apply a maximum voltage of 20 mV and a current of 100 mA.	10 milliohms MAXIMUM [initial]
2	Contact Resistance of Wire Termination (Low Level)	Terminate the applicable wire to the terminal and measure wire using a voltage of 20 mV and a current of 100 mA.	2 milliohms MAXIMUM [initial]
3	Insulation Resistance	Unmate & unmount connectors: apply a voltage of 500 VDC between adjacent terminals and between terminals to ground.	1000 Megohms MINIMUM
4	Dielectric Withstanding Voltage	Unmate connectors: apply a voltage of {two times the rated voltage plus 1000 volts} VAC for 1 minute between adjacent terminals and between terminals to ground.	No breakdown
5	Capacitance	Measure between adjacent terminals at 1 MHz.	1.2 picofarads MAXIMUM
6	Temperature Rise (via Current Cycling)	Mate connectors: measure the temperature rise at the rated current after: 1) 96 hours (steady state) 2) 240 hours (45 minutes ON and 15 minutes OFF per hour) 3) 96 hours (steady state)	Temperature rise: +30°C MAXIMUM



[MOLEX KK 396 WEB PAGE](#)

[TABLE OF CONTENTS](#)

REVISION: T1	ECM INFORMATION: EC No: 617983 DATE: 2019/05/27	TITLE: PRODUCT SPECIFICATION .156 CENTER KK CONNECTORS	SHEET No. 10 of 14
DOCUMENT NUMBER: PS-08-50	DOC TYPE: PS	DOC PART: 001	CREATED / REVISED BY: SS06
	CHECKED BY: ISHWARG	APPROVED BY: ISHWARG	

6.2 MECHANICAL PERFORMANCE

ITEM NO.	ITEM	TEST CONDITION	REQUIREMENT
1	Connector Mate and Unmate Forces	Per circuit when mated to a .045 Sq. pin. Mate and Unmate connector (male to female) at a rate of 25 ± 6 mm (1 ± ¼ inch) per minute.	<u>Without Friction Lock</u> 15.6 N (3.5 lbf) MAXIMUM insertion force & 1.8 N (0.40 lbf) MINIMUM withdrawal force
			<u>With Friction Lock</u> 16.8 N (3.78 lbf) MAXIMUM insertion force & 4.0 N (0.90 lbf) MINIMUM withdrawal force
2	Terminal Insertion Force (into Housing)	Apply an axial insertion force on the terminal at a rate of 25 ± 6 mm (1 ± ¼ inch) per minute. (Forces will change with plating's and materials.)	17.8 N (4.0 lbf) MAXIMUM insertion force
3	Terminal Retention Force (in Housing)	Axial pullout force on the terminal in the housing at a rate of 25 ± 6 mm (1 ± ¼ inch) per minute. (Forces will change with plating's and materials.)	35.6 N (8.0 lbf) MINIMUM withdrawal force
4	Durability	Mate connectors up to 25 cycles at a maximum rate of 10 cycles per minute prior to Environmental Tests.	10 milliohms MAXIMUM (change from initial)
5	Vibration (Random)	Mate connectors and vibrate per EIA 364-28, test condition VII.	10 milliohms MAXIMUM (change from initial) & Discontinuity < 1 microsecond
6	Shock (Mechanical)	Mate connectors and shock at 50 g's with ½ sine wave (11 milliseconds) shocks in the ±X,±Y,±Z axes (18 shocks total).	10 milliohms MAXIMUM (change from initial]) & Discontinuity < 1 microsecond



[MOLEX KK 396 WEB PAGE](#)

[TABLE OF CONTENTS](#)

REVISION: T1	ECM INFORMATION: EC No: 617983 DATE: 2019/05/27	TITLE: PRODUCT SPECIFICATION .156 CENTER KK CONNECTORS	SHEET No. 11 of 14
DOCUMENT NUMBER: PS-08-50	DOC TYPE: PS	DOC PART: 001	CREATED / REVISED BY: SS06
	CHECKED BY: ISHWARG	APPROVED BY: ISHWARG	

MECHANICAL PERFORMANCE (CONTD.)			
ITEM NO.	ITEM	TEST CONDITION	REQUIREMENT
7	Wire Pullout Force (Axial)	Apply an axial pullout force on the wire at a rate of 25 ± 6 mm ($1 \pm \frac{1}{4}$ inch) per minute. (For maximum performance use Molex application tooling with stranded tinned copper wire)	Wire pullout force depends on crimp tooling. See relevant Molex Application Tooling Specification for requirements.
8	Normal Force	Apply a perpendicular force.	7.34 N (748 grams) average

6.3 ENVIRONMENTAL PERFORMANCE

ITEM NO.	ITEM	TEST CONDITION	REQUIREMENT	
1	Shock (Thermal)	Mate connectors; expose to 5 cycles of:	10 milliohms MAXIMUM (change from initial) & Visual: No Damage	
		<u>Temperature</u> °C		<u>Duration</u> (Minutes)
		-40 °C +0/-3		30
		+25 °C ± 10		5 MAXIMUM
		+105 °C +3/-0		30
2	Thermal Aging	Mate connectors; expose to: 96 hours at $105 \pm 2^\circ\text{C}$	10 milliohms MAXIMUM (change from initial) & Visual: No Damage	
3	Humidity (Steady State)	Mate connectors: expose to a temperature of $40 \pm 2^\circ\text{C}$ with a relative humidity of 90-95% for 96 hours. Note: Remove surface moisture and air dry for 1 hour prior to measurements.	10 milliohms MAXIMUM (change from initial) & Dielectric Withstanding Voltage: No Breakdown at 500 VAC & Insulation Resistance: 1000 Megohms MINIMUM & Visual: No Damage	



[MOLEX KK 396 WEB PAGE](#)

[TABLE OF CONTENTS](#)

REVISION: T1	ECM INFORMATION: EC No: 617983 DATE: 2019/05/27	TITLE: PRODUCT SPECIFICATION .156 CENTER KK CONNECTORS	SHEET No. 12 of 14
DOCUMENT NUMBER: PS-08-50	DOC TYPE: PS	DOC PART: 001	CREATED / REVISED BY: SS06
	CHECKED BY: ISHWARG	APPROVED BY: ISHWARG	

ENVIRONMENTAL PERFORMANCE (CONTD.)			
ITEM NO.	ITEM	TEST CONDITION	REQUIREMENT
4	Humidity (Cyclic)	Mate connectors: cycle per EIA-364-31: 24 cycles at temperature $25 \pm 3^\circ\text{C}$ at $80 \pm 5\%$ relative humidity and $65 \pm 3^\circ\text{C}$ at $50 \pm 5\%$ relative humidity; dwell time of 1.0 hour; ramp time of 0.5 hours. {Note: Remove surface moisture and air dry for 1 hour prior to measurements.}	10 milliohms MAXIMUM (change from initial) & Dielectric Withstanding Voltage: No Breakdown at 500 VAC & Insulation Resistance: 1000 Megohms MINIMUM & Visual: No Damage
5	Solderability	Per SMES-152	Solder coverage: 95% MINIMUM (per SMES-152)
6	Solder Resistance	Dip connector terminal tails in solder: Solder Duration: 5 ± 0.5 seconds; Solder Temperature: $230 \pm 5^\circ\text{C}$	Visual: No Damage to insulator material
7	Cold Resistance	Mate connectors: Duration: 96 hours; Temperature: $-40 \pm 3^\circ\text{C}$	10 milliohms MAXIMUM (change from initial) & Visual: No Damage
8	Corrosive Atmosphere: Flowing Mixed Gas (FMG)	Mate connectors: Test per EIA-364-65, method 2A	10 milliohms MAXIMUM (change from initial) & Visual: No Damage



[MOLEX KK 396 WEB PAGE](#)

[TABLE OF CONTENTS](#)

REVISION: T1	ECM INFORMATION: EC No: 617983 DATE: 2019/05/27	TITLE: PRODUCT SPECIFICATION .156 CENTER KK CONNECTORS	SHEET No. 13 of 14
DOCUMENT NUMBER: PS-08-50	DOC TYPE: PS	DOC PART: 001	CREATED / REVISED BY: SS06
	CHECKED BY: ISHWARG	APPROVED BY: ISHWARG	

7.0 SOLDER INFORMATION

[Molex Solderability Specification SMES-152](#)
([Click Here](#))

7.1 SOLDER PROCESS TEMPERATURES

Wave Solder: 235°C Max

8.0 PACKAGING

Parts shall be packaged to protect against damage during normal handling, transit and storage. Refer Molex.com specific part number webpage to get the exact packaging document for that item.

9.0 CABLE TIE AND/OR WIRE TWIST LOCATION

Circuit Sizes			Dimension T Minimum
2	4	6	0.50" (12.7mm)
	8		0.75" (19.1mm)
10		12	1.00" (25.40mm)
14		16	1.25" (31.75mm)
18		20	1.50" (38.09mm)
22		24	1.75" (44.45mm)

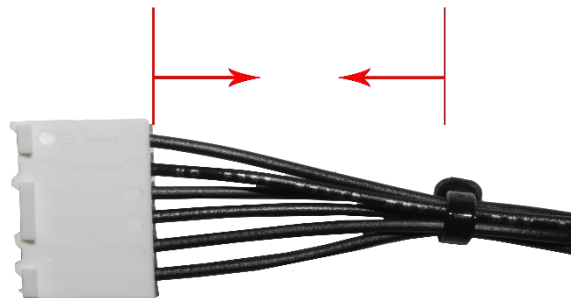

The "T" dimension defines a "free" length of wire, or a length of wire that is not subject to significant bias by external factors such as a wire tie, wire twisting, or other means of bending or deforming of the wires that repositions them from their natural relaxed state or location where they enter the housing. Wires are to be dressed in such a manner to allow the terminals to float freely in the pocket. This dimension is general recommendation and may need to be adjusted for different wire gauges and wire type and insulation thickness and insulation material.



[MOLEX KK 396 WEB PAGE](#)

[TABLE OF CONTENTS](#)

REVISION: T1	ECM INFORMATION: EC No: 617983 DATE: 2019/05/27	TITLE: PRODUCT SPECIFICATION .156 CENTER KK CONNECTORS	SHEET No. 14 of 14
DOCUMENT NUMBER: PS-08-50	DOC TYPE: PS	DOC PART: 001	CREATED / REVISED BY: SS06
	CHECKED BY: ISHWARG	APPROVED BY: ISHWARG	

CKT	PARTS PER 96707-0012	PARTS PER MASTER CARTON 96708-0007 DU
2	1000	8000
3	1000	8000
4	600	4800
5	400	3200
6	300	2400
7	200	1600
8	200	1600
9	200	1600
10	200	1600
11	150	1200
12	100	800
13	100	800
14	100	800
15	100	800
16	100	800
17	100	800
18	100	800
19	100	800
20	100	800
21	100	800
22	100	800
23	100	800
24	100	800

RANDOM

ALIGNED

2-11 CKT PARTS MAY BE RANDOM.
12-24 CKT PARTS TO BE ALIGNED AS SHOWN

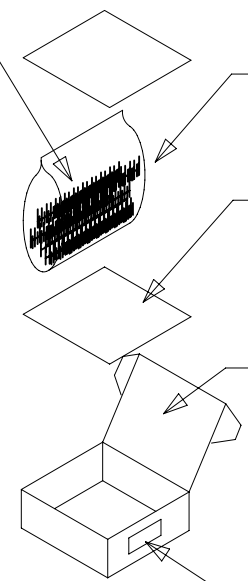

ANTI-STAT BAG(S)
85091016 OR EQUIVALENT

FOAM NUMBER: 96720-0001
OR EQUIVALENT
TYP 2 PER BOX

PRIMARY BOX:
NUMBER: 96707-0012

LABEL:
PER ES-40000-7012

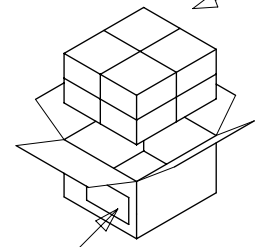

LABEL:
PER ES-40000-7012
(8) 96707-0012
PRIMARY BOXES
PER 96708-0007
CARTON

THIS DRAWING CONTAINS INFORMATION THAT IS PROPRIETARY TO MOLEX ELECTRONIC TECHNOLOGIES, LLC AND SHOULD NOT BE USED WITHOUT WRITTEN PERMISSION										
SYMBOLS	DIMENSION UNITS		SCALE		CURRENT REV DESC: DRAWING UPDATION					
	IN/MM		NTS		molex BULK PACKAGING SPECIFICATION KK 41671 PACKAGING DESIGN DRAWING					
GENERAL TOLERANCES (UNLESS SPECIFIED)										EC NO: 612141
ANGULAR TOL ± °					DRWN: SS06 2019/01/28					
4 PLACES ±					CHK'D: ISHWARG 2019/02/15					
3 PLACES ±					APPR: ISHWARG 2019/02/15					
2 PLACES ±					INITIAL REVISION:					
1 PLACE ±					DRWN: KSAMIEC 2001/11/19					
0 PLACES ±					APPR: YMARGULI 2001/11/19					
DRAFT WHERE APPLICABLE MUST REMAIN WITHIN DIMENSIONS					THIRD ANGLE PROJECTION	DRAWING	SERIES	MATERIAL NUMBER	CUSTOMER	SHEET NUMBER
						A4-SIZE	41671	NA	GENERAL MARKET	1 OF 1

DOCUMENT STATUS	P1	RELEASE DATE	2019/02/15	12:20:55
-----------------	----	--------------	------------	----------